

XYG440-F 2軸/2-axis

▶ 螺桿驅動
Ball Screw Drive



此圖僅供參考，出貨規格詳見尺寸圖面
The picture is just for the reference. Please check the actual dimensions on the drawing.

※標準連結滑台不提供同動精度
Assembly accuracy is not guaranteed for the standard multi-axis system.

最大行程 Maximum Stroke

X軸
X axis 1250mm

Z軸
Z axis 550mm

最高速度 Maximum Speed

X軸
X axis 1000mm/s

Z軸
Z axis 500mm/s

AC伺服馬達容量 AC Servo Motor Output

X軸
X axis 400W

Z軸
Z axis 400W+煞車

基本仕様 Specification

項目 Item	X軸 X axis	Z軸 Z axis
軸型式 Model Type	HPG12	HPG12
位置重複精度 Repeatability (mm)	±0.01	±0.01
螺桿導程 Ball Screw Lead (mm)	20	10
最高速度 Maximum Speed (mm/s) ※3	1000	500
標準行程(50間隔) Stroke 50 mm Pitch (mm)	100~1250	50~550
AC伺服馬達容量 AC Servo Motor Output (w)	400	400+煞車 Brake
使用環境 Environment	0~40°C, 85%RH Below	

※3: 最高速度(mm/s)是以伺服馬達最高轉速3000rpm/min為基準。
Maximum speed is based on the AC servo motor's 3000RPM.

最大可搬重量 Maximum Payload

Z軸行程 Z Stroke (mm)	50~550
Z軸荷重 Z Payload (kg)	22

型號表示方式 Ordering Method

XYG440 - F 1 - 400 - 350 - T - C - 0001

本體型號
Model

特注仕様
Special Order No.

■ 連結方式
Combination

F 十字型 XZ Type

■ 組合方向
Combination Direction

1
3

■ X軸行程
X Stroke

100~1250mm
50間隔 50 mm Pitch

■ Z軸行程
Z Stroke

50~550mm
50間隔 50 mm Pitch

■ 電機安裝標準
Motor installation

T 通用馬達安裝標準:
三菱 Mitsubishi
台達 Delta
安川 Yaskawa
匯川 Inovance
等等 Etc
P 松下馬達安裝標準

■ 出貨方式
Delivery Method

C 連結出貨 By Set
K 單軸出貨 By Kit

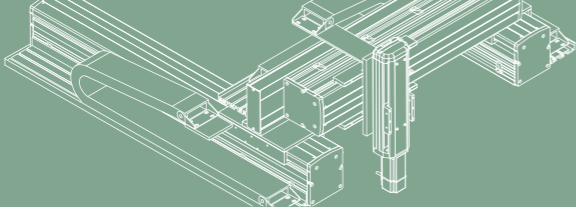

XYG440-F1 尺寸圖 Size

單位 Unit: mm

F1

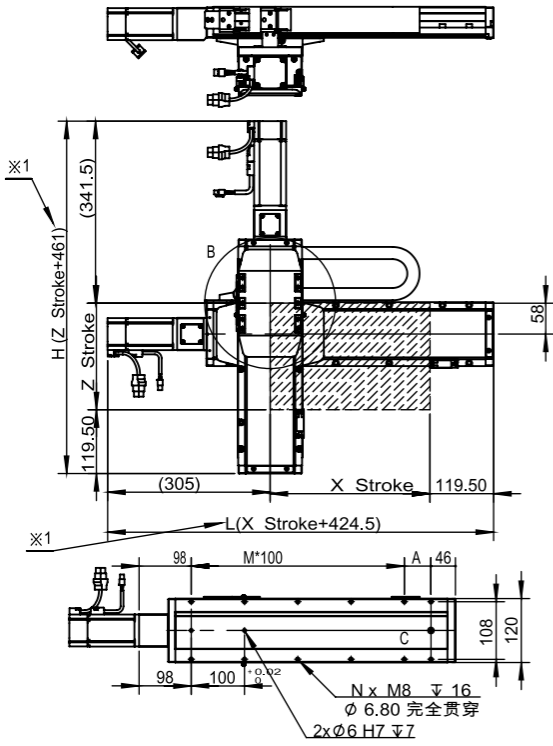

X-Cable Chain

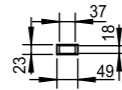

B-Detail View

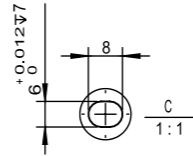
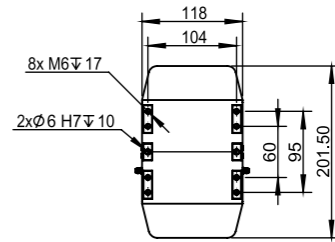

※1: Z軸總高度會依搭配的馬達廠牌及型號而變動。
The total height of Z-axis is depends on different motor's brands.

X軸行程 X Stroke (mm)	100	150	200	250	300	350	400	450	500	550	600	650	700	750	800	850	900	950	1000	1050	1100	1150	1200	1250	
L	524.5	574.5	624.5	674.5	724.5	774.5	824.5	874.5	924.5	974.5	1025.5	1075.5	1125.5	1175.5	1225.5	1275.5	1325.5	1375.5	1425.5	1475.5	1525.5	1575.5	1625.5	1675.5	
A	50	100	50	100	50	100	50	100	50	100	50	100	50	100	50	100	50	100	50	100	50	100	50	100	
M	2	2	3	3	4	4	5	5	6	6	7	7	8	8	9	9	10	10	11	11	12	12	13	13	
N	8	8	10	10	12	12	14	14	16	16	18	18	20	20	22	22	24	24	26	26	28	28	30	30	
最高使用速度 Maximum Speed (mm/s)※4	1000																900	800	700	667	633	600	533	500	467

Z軸行程 Z Stroke (mm)	50	100	150	200	250	300	350	400	450	500	550
H	511	561	611	661	711	761	811	861	911	961	1011
最高使用速度 Maximum Speed (mm/s)※4	500										

※4: 最高使用速度代表該行程內可使用的最高安全速度，若超過此速度，滑台可能有嚴重共振產生。
Maximum speed is refers to the highest safe speed that can be used in stroke, if more than the standard speed, it may occur serious resonance.

連結方向 Combination Direction

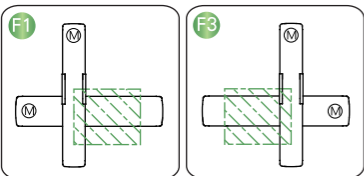

配件規格 Spec. Details

X軸詳細規格 X-axis Detail Spec.	→P055	Y軸詳細規格 Y-axis Detail Spec.	-
Z軸詳細規格 Z-axis Detail Spec.	→P055	馬達廠牌選定 Motor Brand Options	→P427